



PALADIN ENERGY LTD

NANO-FILTRATION TECHNOLOGY FOR REAGENT RECOVERY

BMS ENGINEERS
Building Membrane Solutions



Kayelekera Uranium Mine

- **Kayelekera** is located in northern Malawi.
- Kayelekera Mine is owned 100% by **Paladin (Africa) Limited (PAL)**, a subsidiary of **Paladin Energy Limited**.
 - The mine design capacity is 3.3Mlb U_3O_8 per annum
 - Acid leach process utilising high pulp density Resin In Pulp (hdRIP) technology.
 - Plant on Care & Maintenance since April 2014 due to market conditions (price)
 - Uranium is precipitated from acidic Concentrated Eluate (CE) which requires the acid to be neutralised at significant cost.



Kayelekera's Nano-Filtration Acid Recovery Plant (ARP)

- Concept developed in 2010
- Initial testwork in 2011 was encouraging using synthetic liquors
- Pilot plant operated at site in 2012 and provided confirmation of concept as well as design data
- Detailed engineering commenced October 2012 and capital commitment December 2012
- Hot commissioning commenced 21st October 2013 and design criteria achieved 25th October 2013

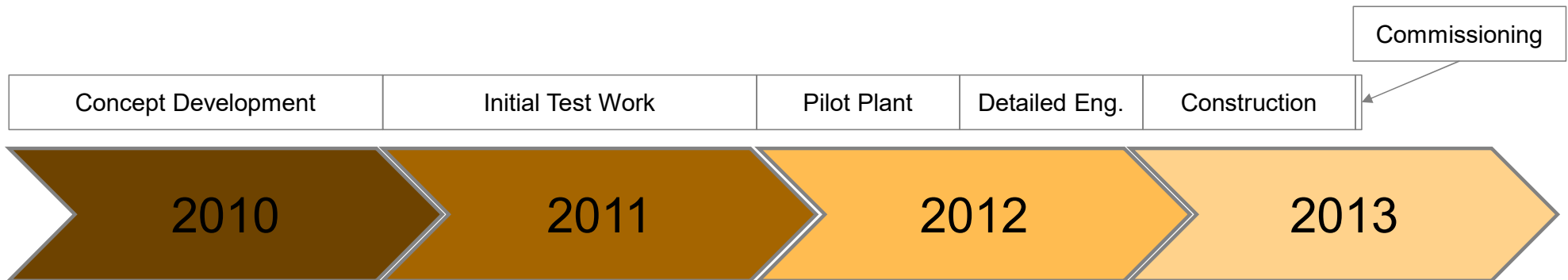

CONCEPT TO COMPLETION IN 3½ YEARS

Kayelekera's Nano-Filtration Acid Recovery Plant (ARP)

- Recovery of over 40 t/day (equivalent) of 98% sulphuric acid
 - Typical feed flow of 30 m³/hr @ 1M sulphuric acid
- Equivalent stoichiometric saving of neutralisation reagents.
- Uranium concentration to precipitation circuit increased from ~10 g/l to ~40 g/l
 - Improved refinery performance due to longer residence times
 - Improved final product contaminant removal.
- Project cost of US\$5 M
 - Project on time and within budget
 - Net operating cost savings of over US\$3 per lb U₃O₈.
 - Cash payback period (including all operating costs) of 7 months on reagent savings alone.
 - Significant other consequential benefits.
- Process now subject to patent and BMS hold commercial rights



Patented Technology – Reagent Recovery from Uranium Process

One Application – Sulfuric Acid recovery

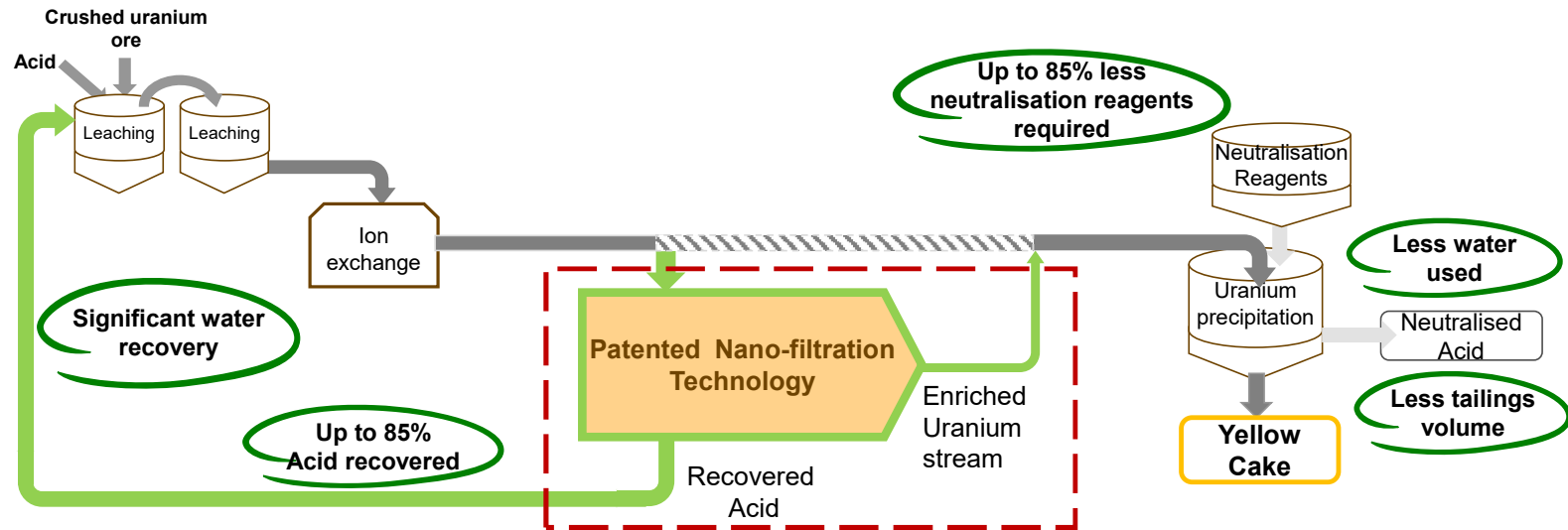

- 1 Elution Acid**
- Up to 85% of elution acid recovered and reusable
 - Significant acid cost reduction
 - Acid supply logistics reduced significantly
 - Site becomes acid self-sufficient

- 2 Neutralisation**
- Neutralisation reagent proportionate to recovered acid
 - Significant neutralisation cost savings

- 3 Water balance & Tailings**
- Elution acid make-up water reduced by up to 85%
 - Reduced tailings volume due to reduced acid, other reagents and water addition to circuit

Project Piloting



- **Three pilot campaigns were undertaken to generate design data, identify membrane life and assess main plant design,**
- **Current BMS Personnel undertook all site testwork.**

Project Membranes

- Multiple membrane types tested:
 - Acid “resistant” membranes
 - Shorter life
 - Excellent uranium rejection
 - Low membrane cost
 - Acid “proof” membranes
 - Longer life
 - Lower uranium rejection
 - High membrane cost (~6x acid resistant cost)
- Test housing on main plant
 - Enables continuous membrane testing and ongoing optimisation.



Modified Membranes

- Improvements based on operational performance and process requirements,
 - Greater than 10% flux improvement achieved with modified membranes.



BMS MEMBRANES
Building Membrane Solutions
www.bmse.com.au A division of BMS Engineers info@bmse.com.au

Project Delivery – remote site

- **Plant fabricated in Johannesburg**
- **ARP was built to be fully transportable**
 - 3 containerised skids
 - 5 separate 316SS tanks
- **Complete FAT and Wet Commissioning prior to dispatch**
 - PLC programming fully tested during FAT,
 - All pumps operated,
 - All lines leak tested,
 - CIP skid fully tested.



Project Delivery – remote site application



Tanks and skids transported by truck from South Africa to Kayelekera Mine in Malawi

Project Delivery – remote site application



Pad installed while Skids being fabricated



Skid installation completed within weeks

Project Delivery – remote site application



Full operational performance within 5 days from first plant feed

Plant Performance

Inputs:

- **Feed stream:** Concentrated Eluant (CE) from RIP
- **Design Flowrate:** 30 m³/hr
- **Composition:** 100 g/l H₂SO₄, 10 g/l U₃O₈

Objectives:

- Recover acid from CE for re-use

Design Outputs:

ARP Produced two streams

- Permeate (*recovered acid*) – 75% of CE volume
- Concentrate (*uranium rich*) – 25% of CE volume

Plant Output Streams:

- Permeate (*recovered acid*) re-used in leach process,
- Concentrate (*uranium rich*) progressed to CE neutralisation and Uranium Precipitation.



Project Findings

- **Uranium concentrations increased 4 fold in concentrate**
 - Can achieve 5 fold
- **Average membrane life,**
 - dependent on acid concentration
 - Achieved significantly longer life than used for project justification
- **No cleaning on NF membranes required**
- **Minimal NF scaling observed**



Langer Heinrich Uranium mine – Another Membrane application

Paladin Energy and **BMS Engineers** designed, installed and commissioned a second Nano-filtration plant for the recovery of Sodium Bicarbonate at Langer Heinrich, Namibia



Patented Technology – Reagent Recovery from Uranium Process

A Further Application – Bicarbonate Recovery (BRP)

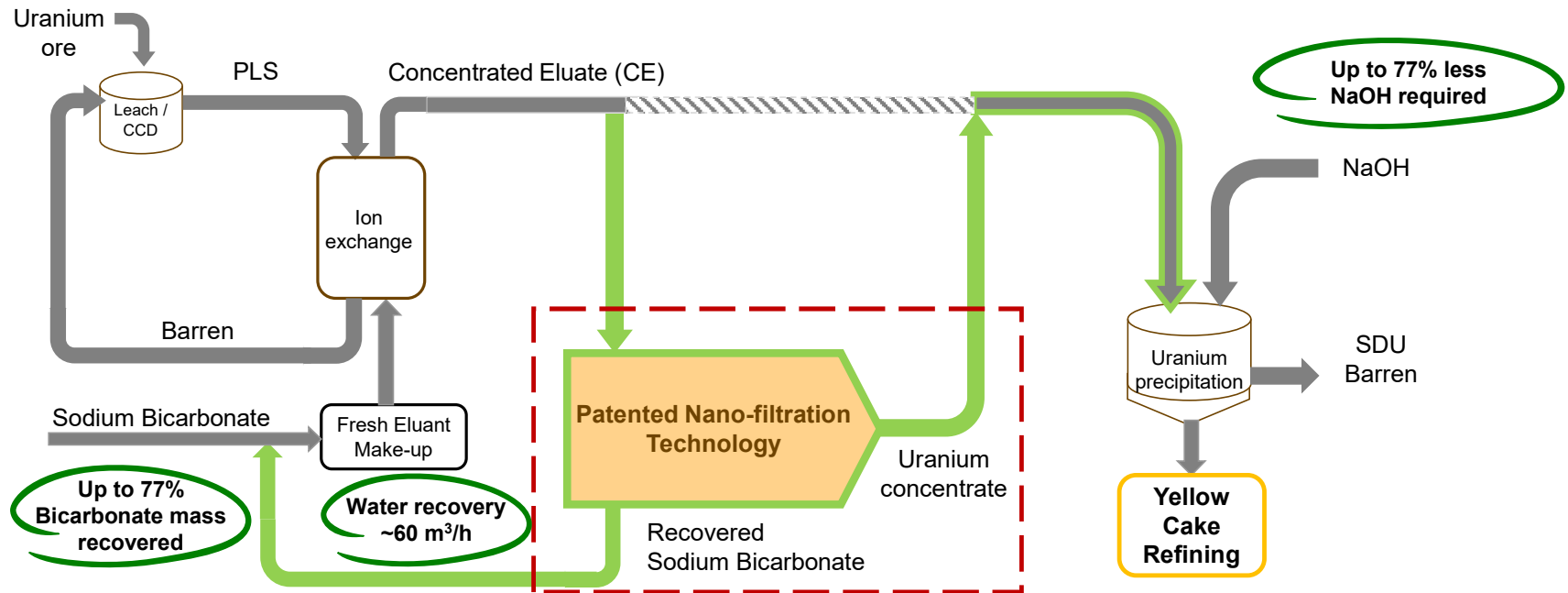

1

Fresh Eluant

- Up to 77% of sodium bicarbonate recovered and recycled to Fresh Eluant make-up
- Significant sodium bicarbonate savings

2

Precipitation

- Neutralisation reagent savings proportional to recovered sodium bicarbonate
- Significant neutralisation reagent cost saving

3

Fresh Water Input

- Fresh Eluant make-up water addition reduced by up to 87% (60 m³/h)

Bicarbonate Recovery Plant (BRP)

- Concept developed in 2010
- Initial testwork in 2011 was encouraging using plant liquors
- Pilot plant operated at site in 2012 and provided confirmation of concept as well as design data
- Engineering commenced November 2013 and capital commitment May 2014
- Hot commissioning commenced 11th March 2015 and design criteria achieved 12th March 2015
- 200% of design criteria achieved September 2015

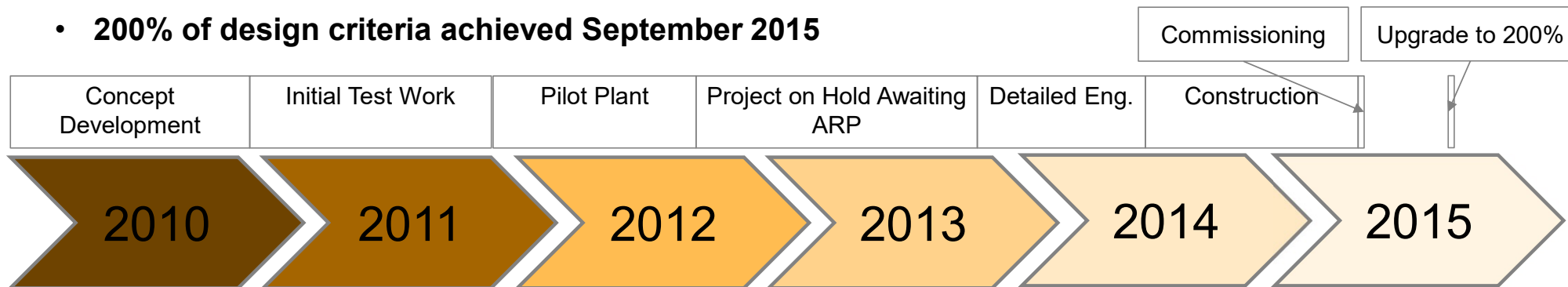

APPROVAL TO COMPLETION IN 2 YEARS

Bicarbonate Recovery Plant (BRP)

Patented nano-filtration technology applied to the alkali uranium process

BMS and Paladin commissioned the BRP at Langer Heinrich in March 2015

- **BMS Engineers and Paladin** have designed and commissioned the world's first Bicarbonate Recovery Plant (BRP), recovering sodium bicarbonate from a uranium concentrated eluate stream using NF membranes.
- The membrane plant was commissioned in March 2015. The plant has exceeded its design bicarbonate recovery and has resulted in a significant reduction in reagent demand.
- The BRP has also significantly altered the circuit water balance and facilitated improved process recovery.
- Other consequential benefits have been significant.



Bicarbonate Recovery Plant (BRP)

BMS Engineers/Paladin have successfully undertaken:

- **Pilot plant trials for BRP concept**
- **Detailed design**
- **Commissioning**
- **Training of site personnel in BRP operations and maintenance**
- **Ongoing remote technical support**



*“...BRP successfully commissioned in March and operating above design. The extent of this project’s success has far-reaching implications for the Langer Heinrich operation now and into the future. BRP is expected to exceed design benefit by up to 100% and establish a new paradigm in carbonate uranium processing...” **

*Paladin website Q1 2015 ASX report

Bicarbonate Recovery Plant (BRP)

Based on plant performance, operational improvement (Enhancement 4) was undertaken and improved plant bicarbonate recovery to 200% of nameplate at minimal cost*.

- BRP Enhancement 4 now operational

- ✓ Capital Cost of additional <US\$100k of our original capital cost of US\$6.8M
- ✓ Recovery of sodium bicarbonate now exceeds 200% of design
- ✓ Total operating cost saving now >US\$6/lb (>US\$30Mpa)
- ✓ Additional secondary benefits

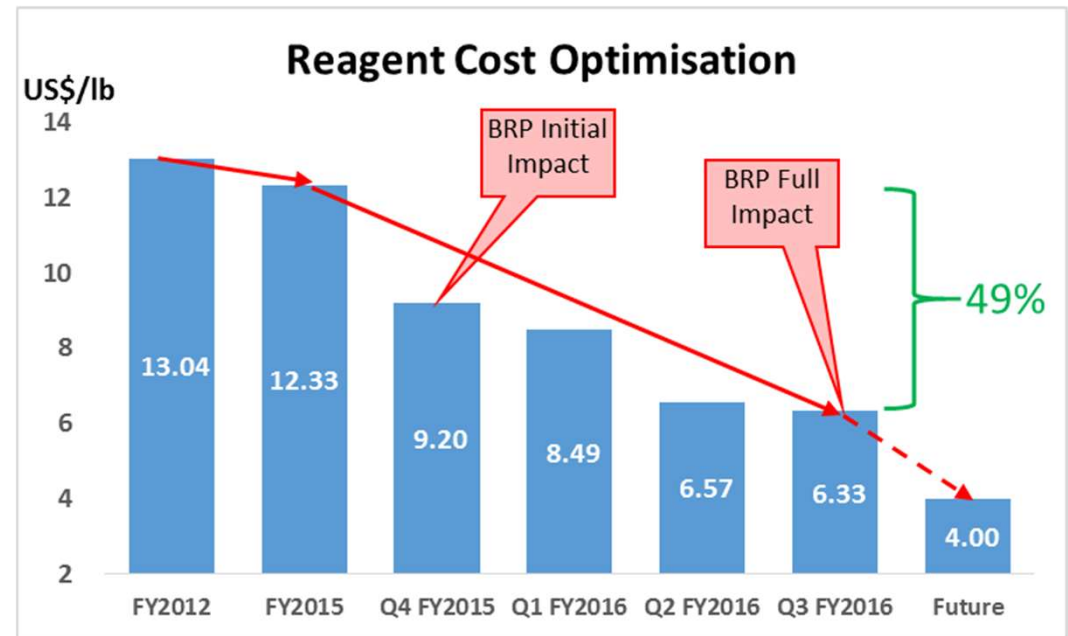

*Paladin 2015 AGM Report

Conclusions

- **Paladin has completed the development of a truly innovative uranium processing change**
 - **The process is broadly applicable in both acid and alkali environments**
 - **We have been able to patent the process involved**
 - **The impact on processing costs has been dramatic and creates a new paradigm for uranium hydrometallurgy**
- **This could not have been achieved without the engineering expertise of BMS who must now be considered world leaders in membrane applications within hydrometallurgical processes**
 - **The commissioning periods achieved here (days only) are testament to the level of engineering expertise involved**
 - **BMS hold the commercial exploitation rights to the process and have developed proprietary membranes – knowhow is the key**
- **THERE IS MORE TO COME FROM THIS TECHNOLOGY**

Acknowledgements

- A number of people have been critical to the very successful development of this process and need to be acknowledged:
- **Paladin Employees:**
 - **Darryl Butcher**, EGM – Technical, Project Development
 - **Dr Merrill Ford**, Metallurgy Manager
 - **Paul Boshoff, GM** – Technical, Project Development
 - **Simon Donegan**, Principal Process Engineer
 - **Harry Russell**, Principal Chemist
 - **Deogratias Bukunkwe**, Superintendent – Process Development
- **BMS Employees:**
 - **Mark Peacock**, Principle Engineer
 - **Shana McDougall**, Principle Process Engineer
 - **Paul James**, Field Technician